

CP-USC-TC51ZL6-V3

5MP IR Bullet Camera - 60Mtr.

- 1/2.7" 5MP PS CMOS Image Sensor (0.9407cm)
- Max. 25fps@5MP (16:9 video output)
- DWDR, Day/Night (ICR), 2D-NR, AWB, AGC, BLC, HLC
- 2.7mm ~ 12mm Motorized lens
- IR Range of 60 Mtrs., Smart IR, IP67
- CVI/CVBS/AHD/TVI Switchable



System Overview

Analog cameras can be advantageous in more ways than one – they are economical, especially for large scale setups, and are simple to install. However, one of the major downsides of earlier analog cameras was the image quality, which is critical in the present times. With subsequent technological upgrades over the years, HD resolution was introduced in analog CCTV systems. This served as a major breakthrough as high quality imagery was only available in IP system which was comparatively a costlier option.

Another challenge with analog systems was its compatibility constraint. Newer versions of analog cameras would not pair up with older versions. CP PLUS introduced the revolutionary UNI + technology which supported all analog & HD video formats including CVBS.



CP-USC-TC51ZL6-V3

5MP IR Bullet Camera - 60Mtr.

Functions

IR LED

Numerous IR LEDs provide detailed images even in very low light conditions. These LEDs adjust the infrared intensity for distinct images in dark environments for up to 60mtrs.

UNI+ Technology

CP PLUS Analog HD cameras offer compatibility across all the available technologies - CVBS, TVI, HDCVI, AHD and HDx, making upgrading simple and hassle-free.

Power Protection

With a voltage tolerance range of ± 30 , these cameras are suitable even in fluctuating power conditions.

Plug & Play

CP PLUS Analog HD cameras are simple to configure and install.

About CP PLUS

The brand that is on its way to lead the world when it comes to the security and surveillance industry, CP PLUS, keeps bombarding the market with the most reliable range of products that have been designed carefully and methodically to automate the whole surveillance and security process, no matter how big your premises are.

It was the initiative to help the public in the area where they are the most vulnerable and to empower the sense of safety in our hearts that had conceptualized CP PLUS. And embarking on its mission to make the world a safer and more secure place has taken the brand's journey to unprecedented levels even when compared to international competitors.



CP-USC-TC51ZL6-V3

5MP IR Bullet Camera - 60Mtr.

Feature	Specification
Image Sensor	1/2.7" 5MP Progressive Scan CMOS (0.9407cm)
Minimum Illumination	0.01 Lux/F1.6; 30IRE; 0 Lux IR on
Shutter Speed	PAL: 1/25~1/100000s ; NTSC: 1/30~1/100000s
Lens	2.7mm~12mm
Lens Type	Motorized
Iris Type	Fixed iris
Close Focus Distance	0.5 m
S/N Ratio	>65dB
Resolution	5MP (2880 × 1620); 4MP (2560 × 1440); 1080P (1920 × 1080); 960H (960 × 576/960 × 480)
Mount Type	Φ14
Max. Aperture	F1.6
Angle of View	Diagonal: 39°–130° Horizontal: 34°–107° Vertical: 19°–55°
Whit Balance	Auto/ Manual
DORI Distance	2.7mm: 69.0m (Detect) 27.6m(Observe) 13.8m(Recognize) 6.9m(Identify) 3.6mm: 191.6m (Detect) 76.64m(Observe) 38.32m(Recognize) 19.16m(Identify)
Back Light Compensation	BLC/HLC/DWDR
Video Output	Video output choices of CVI/TVI/AHD/CVBS by one BNC port
Video Streaming	CVI: PAL: 5MP@25fps; 4MP@25fps; 1080P@25fps; NTSC: 5MP@25fps; 4MP@30fps; 1080P@30fps; AHD: PAL: 4MP@25fps; NTSC: 4MP@30fps; TVI: PAL: 4MP@25fps; NTSC: 4MP@30fps; CVBS: 960H
ICR	Auto switch by ICR
IR	IR Range of 60 Mtr.

Feature	Specification
Gain Control	Auto/ Manual
Noise Reduction	2D-NR
Mirror	Off/On
Privacy Masking	Off / On (8 area, rectangle)
Smart IR	Yes
Weatherproof Standard	IP67
Casing	Mental front cover+ plastic main body+ plastic bracket
Operating Temperature	-30°C to +60°C (-22°F to +140°F)/ < 95% (non-condensation)
Storage Temperature	-30°C to +60°C (-22°F to +140°F))/ < 95% (non-condensation)
Power Source	12V DC ±30%
Power Consumption	Max 6.6W (12V DC; IR on)
Dimension	243.5 mm × 90.7 mm × 90.7 mm (9.59" × 3.57" × 3.57")
Weight	0.39 kg

Dimensions (mm/inch)

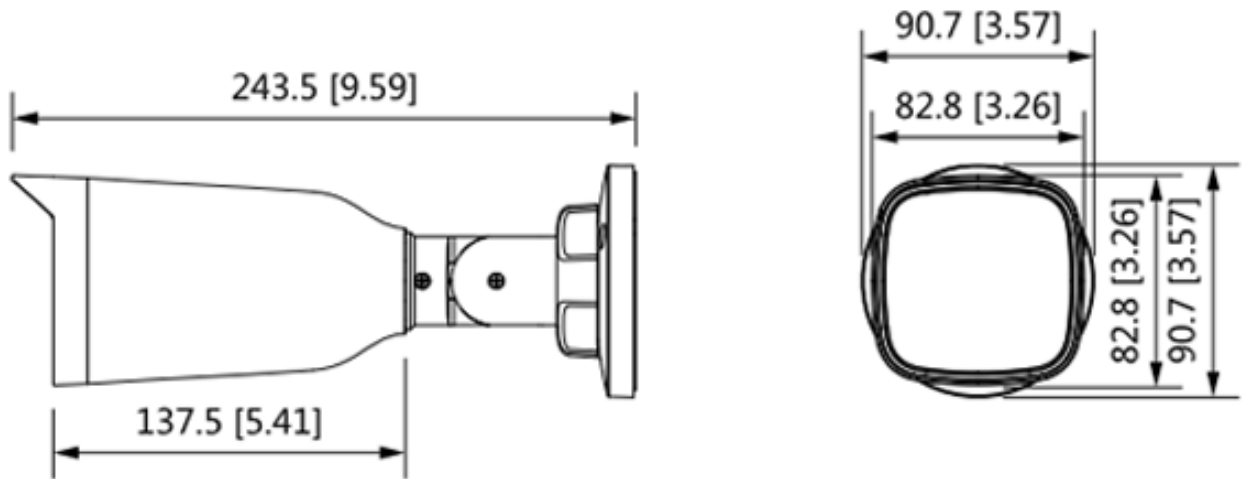

Accessories : Optional

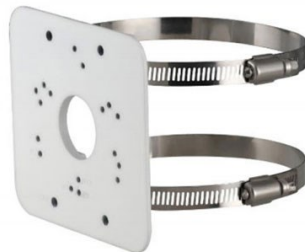

CP-UA-B2P
Pole Mount